

Figure 1

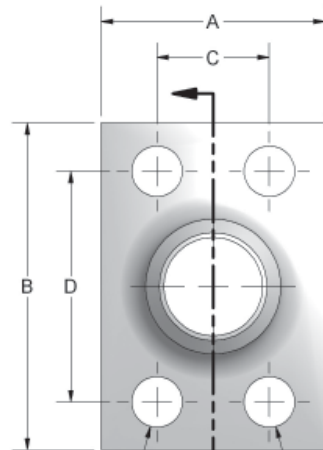

FIG. 1 FIG. 2

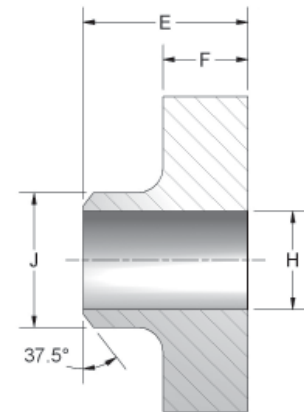

Figure 2

FLOW, NEEDLE & CHECK VALVES

HYDRAULIC BALL VALVES

WELD COUPLINGS

FLANGES

### CODE 62 BUTT WELD - SCHEDULE 80 PIPE

PART NO. O-RING FIG. 1	PART NO. FLAT FACE FIG. 2	PIPE SIZE	PAD SIZE	A	B	C	D	E	F	G	H	J	K	L UNC-2B	MOUNTING HARDWARE	
															O-RING	SHCS
W28-12-SS	W26-12-SS	.75	.75	1.94	2.81	.937	2.000	1.42	.83	1.250	.744	1.050	.406	3/8-16	214	3/8-16X1.50
W28-16-SS	W26-16-SS	1.00	1.00	2.18	3.19	1.093	2.250	1.61	.83	1.560	.959	1.315	.492	7/16-14	219	7/16-14X1.50
W28-20-SS	W26-20-SS	1.25	1.25	2.44	3.75	1.250	2.625	1.73	.94	1.750	1.280	1.660	.531	1/2-13	222	1/2-13X2.00
W28-24-SS	W26-24-SS	1.50	1.50	2.81	4.44	1.437	3.125	2.17	1.10	2.115	1.502	1.900	.656	5/8-11	225	5/8-11X2.25
W28-32-SS	W26-32-SS	2.00	2.00	3.44	5.25	1.750	3.812	2.48	1.46	2.490	1.941	2.375	.781	3/4-10	228	3/4-10X3.00
*W28-40-SS	*W26-40-SS	2.50	2.50	5.00	6.88	2.312	4.875	2.37	1.50	2.995	2.325	2.875	.940	7/8-9	232	7/8-9X3.00
*W28-48-SS	*W26-48-SS	3.00	3.00	6.00	8.50	2.812	6.000	2.96	2.00	3.615	2.902	3.500	1.190	1-1/8-7	237	1-1/8-7X4.00

### CODE 62 BUTT WELD - SCHEDULE 160 PIPE

PART NO. O-RING FIG. 1	PART NO. FLAT FACE FIG. 2	PIPE SIZE	PAD SIZE	A	B	C	D	E	F	G	H	J	K	L UNC-2B	MOUNTING HARDWARE	
															O-RING	SHCS
W30-12-SS	W29-12-SS	.75	.75	1.94	2.81	.937	2.000	1.42	.83	1.250	.616	1.050	.406	3/8-16	214	3/8-16X1.50
W30-16-SS	W29-16-SS	1.00	1.00	2.18	3.19	1.093	2.250	1.61	.83	1.560	.817	1.315	.492	7/16-14	219	7/16-14X1.50
W30-20-SS	W29-20-SS	1.25	1.25	2.44	3.75	1.250	2.625	1.73	.94	1.750	1.162	1.660	.531	1/2-13	222	1/2-13X2.00
W30-24-SS	W29-24-SS	1.50	1.50	2.81	4.44	1.437	3.125	2.17	1.10	2.115	1.339	1.900	.656	5/8-11	225	5/8-11X2.25
W30-32-SS	W29-32-SS	2.00	2.00	3.44	5.25	1.750	3.812	2.48	1.46	2.490	1.691	2.375	.781	3/4-10	228	3/4-10X3.00
*W30-40-SS	*W29-40-SS	2.50	2.50	5.00	6.88	2.312	4.875	2.37	1.50	2.995	2.127	2.875	.940	7/8-9	232	7/8-9X3.00
*W30-48-SS	*W29-48-SS	3.00	3.00	6.00	8.50	2.812	6.000	2.96	2.00	3.615	2.626	3.500	1.190	1-1/8-7	237	1-1/8-7X4.00

### CODE 62 BUTT WELD - SCHEDULE XXS PIPE

PART NO. O-RING FIG. 1	PART NO. FLAT FACE FIG. 2	PIPE SIZE	PAD SIZE	A	B	C	D	E	F	G	H	J	K	L UNC-2B	MOUNTING HARDWARE	
															O-RING	SHCS
W33-12-SS	W32-12-SS	.75	.75	1.94	2.81	.937	2.000	1.42	.83	1.250	.436	1.050	.406	3/8-16	214	3/8-16X1.50
W33-16-SS	W32-16-SS	1.00	1.00	2.18	3.19	1.093	2.250	1.61	.83	1.560	.601	1.315	.492	7/16-14	219	7/16-14X1.50
W33-20-SS	W32-20-SS	1.25	1.25	2.44	3.75	1.250	2.625	1.73	.94	1.750	.898	1.660	.531	1/2-13	222	1/2-13X2.00
W33-24-SS	W32-24-SS	1.50	1.50	2.81	4.44	1.437	3.125	2.17	1.10	2.115	1.102	1.900	.656	5/8-11	225	5/8-11X2.25
W33-32-SS	W32-32-SS	2.00	2.00	3.44	5.25	1.750	3.812	2.48	1.46	2.490	1.505	2.375	.781	3/4-10	228	3/4-10X3.00
*W33-40-SS	*W32-40-SS	2.50	2.50	5.00	6.88	2.312	4.875	2.37	1.50	2.995	1.773	2.875	.940	7/8-9	232	7/8-9X3.00
*W33-48-SS	*W32-48-SS	3.00	3.00	6.00	8.50	2.812	6.000	2.96	2.00	3.615	2.302	3.500	1.190	1-1/8-7	237	1-1/8-7X4.00

\*3000 PSI Max Working Pressure