

Figure 1

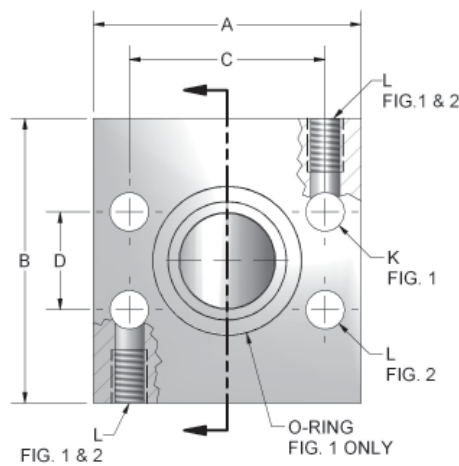

Figure 2

CODE 61 TEE JUNCTION BLOCK

| PART NO. O-RING FIG. 1 | PART NO. FLAT FACE FIG. 2 | PAD SIZE | A | B | C | D | E | F | G | H | J | K | L UNC-2B | MOUNTING HARDWARE | |
|------------------------------|---------------------------------|-------------|------|------|-------|-------|------|------|------|-------|------|------|-------------|----------------------|--------------|
| | | | | | | | | | | | | | | O-RING | SHCS |
| W17-12-SS | W16-12-SS | .75 | 2.62 | 2.75 | 1.875 | .875 | 1.38 | 2.25 | 1.22 | 1.250 | .75 | .406 | 3/8-16 | 214 | 3/8-16X3.00 |
| W17-16-SS | W16-16-SS | 1.00 | 2.82 | 3.00 | 2.062 | 1.031 | 1.50 | 2.50 | 1.34 | 1.560 | 1.00 | .406 | 3/8-16 | 219 | 3/8-16X3.25 |
| W17-20-SS | W16-20-SS | 1.25 | 3.19 | 3.50 | 2.312 | 1.188 | 1.75 | 3.00 | 1.56 | 1.750 | 1.25 | .492 | 7/16-14 | 222 | 7/16-14X4.00 |
| W17-24-SS | W16-24-SS | 1.50 | 3.75 | 4.00 | 2.750 | 1.406 | 2.00 | 3.50 | 1.88 | 2.115 | 1.50 | .531 | 1/2-13 | 225 | 1/2-13X4.50 |
| W17-32-SS | W16-32-SS | 2.00 | 4.00 | 4.25 | 3.062 | 1.688 | 2.12 | 4.00 | 2.09 | 2.490 | 2.00 | .531 | 1/2-13 | 228 | 1/2-13X5.00 |

CODE 62 TEE JUNCTION BLOCK

| PART NO. O-RING FIG. 1 | PART NO. FLAT FACE FIG. 2 | PAD SIZE | A | B | C | D | E | F | G | H | J | K | L UNC-2B | MOUNTING HARDWARE | |
|------------------------------|---------------------------------|-------------|------|------|-------|-------|------|------|-------|-------|-------|------|-------------|----------------------|--------------|
| | | | | | | | | | | | | | | O-RING | SHCS |
| W19-12-SS | W18-12-SS | .75 | 2.81 | 3.00 | 2.000 | .937 | 1.50 | 2.50 | 1.310 | 1.250 | .750 | .406 | 3/8-16 | 214 | 3/8-16X3.25 |
| W19-16-SS | W18-16-SS | 1.00 | 3.19 | 3.50 | 2.250 | 1.093 | 1.75 | 3.00 | 1.620 | 1.560 | 1.000 | .492 | 7/16-14 | 219 | 7/16-14X4.00 |
| W19-20-SS | W18-20-SS | 1.25 | 3.75 | 4.00 | 2.625 | 1.250 | 2.00 | 3.50 | 1.880 | 1.750 | 1.250 | .531 | 1/2-13 | 222 | 1/2-13X4.50 |
| W19-24-SS | W18-24-SS | 1.50 | 4.50 | 4.50 | 3.125 | 1.437 | 2.25 | 4.00 | 2.120 | 2.115 | 1.500 | .656 | 5/8-11 | 225 | 5/8-11X5.00 |
| W19-32-SS | W18-32-SS | 2.00 | 5.25 | 5.00 | 3.812 | 1.750 | 2.50 | 5.00 | 2.750 | 2.490 | 1.940 | .781 | 3/4-10 | 228 | 3/4-10X6.00 |