

FLOW, NEEDLE & CHECK VALVES

HYDRAULIC BALL VALVES

WELD COUPLINGS

FLANGES

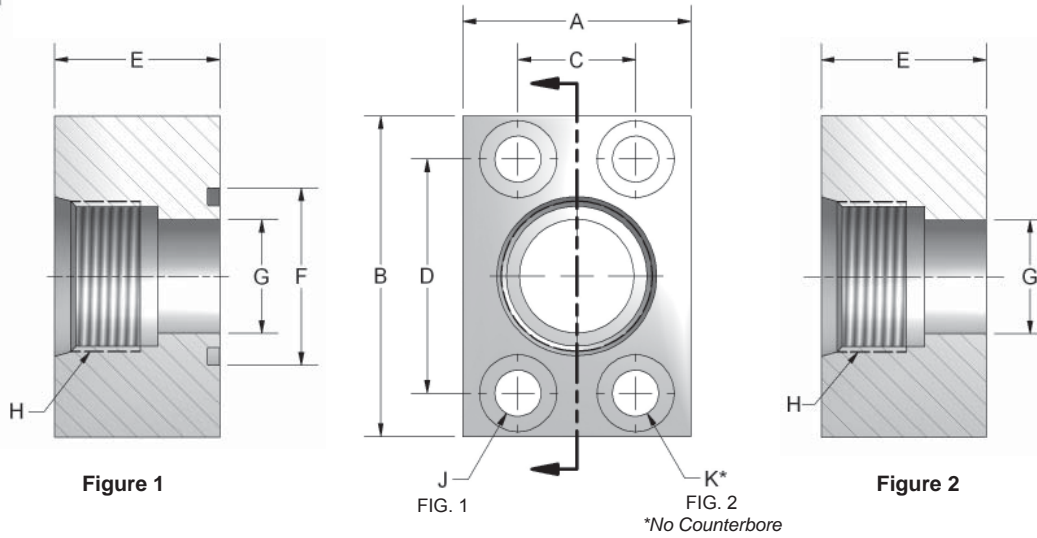

CODE 61 SAE STRAIGHT THREAD

PART NO. O-RING FIG. 1	PART NO. FLAT FACE FIG. 2	TUBE SIZE	PAD SIZE	A	B	C	D	E	F	G	H UN/ UNF-2B	J	K UNC-2B	MOUNTING HARDWARE	
														O-RING	SHCS
W46-8-8-SS	W106-8-8-SS	.50	.50	1.50	2.12	.688	1.500	1.20	1.000	.502	3/4-16	.344	5/16-18	210	5-16-18X1.25
W46-12-12-SS	W106-12-12-SS	.75	.75	1.75	2.62	.875	1.875	1.20	1.250	.752	1 1/16-12	.406	3/8-16	214	3/8-16X1.50
W46-16-16-SS	W106-16-16-SS	1.00	1.00	2.00	2.82	1.031	2.062	1.45	1.560	1.002	1 5/16-12	.406	3/8-16	219	3/8-16X1.50
W46-20-20-SS	W106-20-20-SS	1.25	1.25	2.50	3.19	1.188	2.312	1.45	1.750	1.252	1 5/8-12	.469	7/16-14	222	7/16-14X1.75
W46-24-24-SS	W106-24-24-SS	1.50	1.50	2.75	3.75	1.406	2.750	1.70	2.115	1.502	1 7/8-12	.531	1/2-13	225	1/2-13X2.00
*W46-32-32-SS	W106-32-32-SS	2.00	2.00	3.25	4.00	1.688	3.062	1.70	2.490	2.002	2 1/2-12	.531	1/2-13	228	1/2-13X2.00

*NOTE: 500 PSI max for W46-32-32-SS

CODE 62 SAE STRAIGHT THREAD

PART NO. O-RING FIG. 1	PART NO. FLAT FACE FIG. 2	TUBE SIZE	PAD SIZE	A	B	C	D	E	F	G	H UN/ UNF-2B	J	K UNC-2B	MOUNTING HARDWARE	
														O-RING	SHCS
W48-8-8-SS	W49-8-8-SS	.50	.50	1.75	2.22	.718	1.594	.95	1.000	.502	3/4-16	.344	5/16-18	210	5/16-18X1.25
W48-12-12-SS	W49-12-12-SS	.75	.75	2.00	2.81	.937	2.000	1.20	1.250	.752	1 1/16-12	.406	3/8-16	214	3/8-16X1.50
W48-16-16-SS	W49-16-16-SS	1.00	1.00	2.25	3.19	1.093	2.250	1.45	1.560	1.002	1 5/16-12	.492	7/16-14	219	7/16-14X1.75
W48-20-20-SS	W49-20-20-SS	1.25	1.25	2.75	3.75	1.250	2.625	1.45	1.750	1.252	1 5/8-12	.531	1/2-13	222	1/2-13X1.50
W48-24-24-SS	W49-24-24-SS	1.50	1.50	3.25	4.50	1.437	3.125	1.70	2.115	1.502	1 7/8-12	.656	5/8-11	225	5/8-11X2.00
W48-32-32-SS	W49-32-32-SS	2.00	2.00	4.00	5.25	1.750	3.812	1.70	2.490	2.002	2 1/2-12	.781	3/4-10	228	3/4-10X2.00