

AE3 Series / Three-Way Block Body Threaded

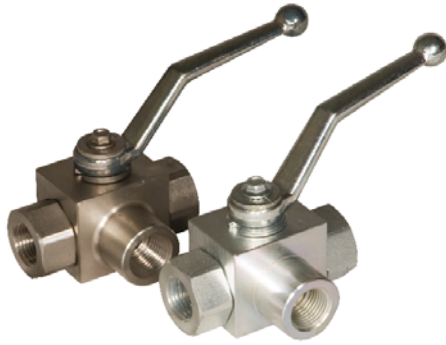

- Carbon steel construction with Silver Trivalent plating
- 316 stainless steel available from stock
- POM seats & Buna O-rings standard on carbon steel valves
- Optional seal materials available for extreme temperature applications & fluid compatibility (Consult Factory)

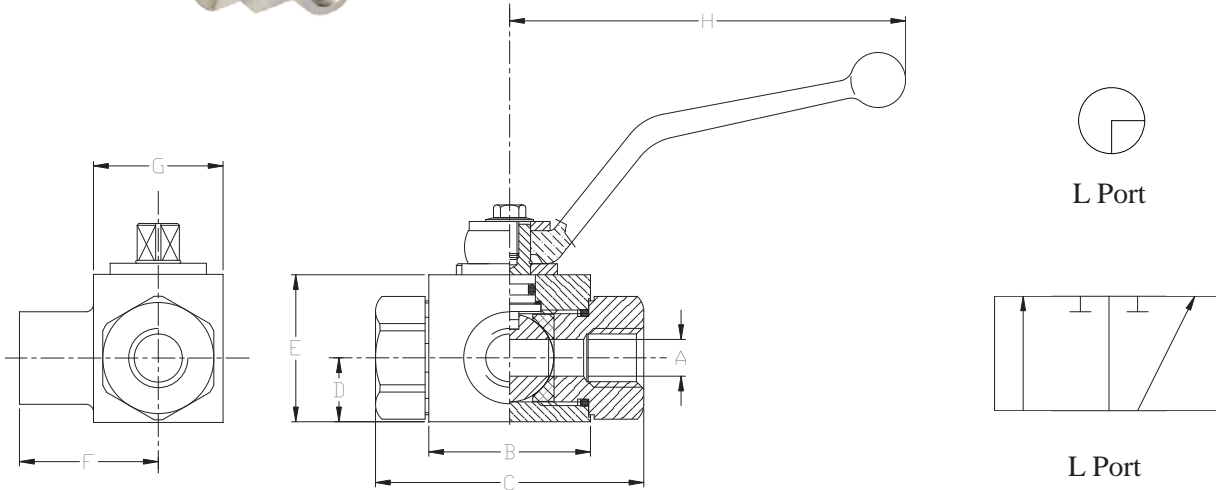

Standard handles supplied are:
Refer to page 47 for details.

1/8" - 1/2"
3/4" - 1 1/2"

C1010ZB
C1200ZB

AE3 SERIES FULL BORE											
NPT	SAE	PSI MAX	A BORE	B	C	D	E	F	G	H	WEIGHT
AE3 L N1/8	N/A	5800	.16	1.65	2.80	.55	1.38	1.32	1.18	4.31	1.1 LBS
AE3 L N1/4	AE3 L S#4	5800	.24	1.65	2.80	.55	1.38	1.32	1.18	4.31	1.1 LBS
AE3 L N3/8	AE3 L S#6	5800	.39	1.73	2.87	.67	1.57	1.46	1.38	4.31	1.5 LBS
AE3 L N1/2	AE3 L S#8	5075	.51	1.89	3.27	.71	1.69	1.57	1.46	4.31	1.8 LBS
AE3 L N3/4	AE3 L S#12	5075	.79	2.44	3.74	.91	2.17	2.05	1.77	7.00	3.3 LBS
AE3 L N1	AE3 L S#16	5075	.98	2.60	4.45	1.14	2.56	2.36	2.17	7.00	5.2 LBS

AE3 SERIES REDUCED BORE											
NPT	SAE	PSI MAX	A BORE	B	C	D	E	F	G	H	WEIGHT
AE3 L N1-1/4R	AE3 L S#20R	5075	.98	2.60	4.76	1.14	2.56	2.42	2.17	7.00	5.5 LBS
AE3 L N1-1/2R	AE3 L S#24R	5075	.98	2.60	4.88	1.14	2.56	2.42	2.17	7.00	6.0 LBS

Only pressurize center port. Side ports should not be pressurized or be exposed to backpressure that is greater than the inlet pressure. Failure to follow these guidelines will result in internal leakage through the valve. For applications requiring pressure applied to side ports, please refer to AE3K Series valves on page 30.

*NPT threads in accordance with ANSI B.1.20.1 specifications.
SAE threads in accordance with SAE J1926/1 specifications.*

FLOW, NEEDLE & CHECK VALVES

HYDRAULIC BALL VALVES

WELD COUPLINGS

FLANGES



AE3 Series / Three-Way Block Body Threaded

Model Code Breakdown

AE3L N1/2 _ - 1 1 D B _

Valve Series

Port Type

L	"Diverter" L-Port
---	-------------------

Connection Type/Size

N	NPT Pipe Thread
S	SAE Straight Thread

Bore Restriction

blank	Unrestricted Bore
R	Restricted Bore

Body & Adapter Material

1	Carbon Steel
2	316 Stainless Steel

Ball & Stem Material

1	Carbon Steel
2	316 Stainless Steel

Locking Kit or Optional Handle Code (See pages 42 & 43)

Adapter & Stem Seals

B	Buna- Standard
V	Viton (Std on S/S)

Ball & Stem Seats

D	POM- Standard
P	PEEK
N	PA612
X	PTFE w/metallic insert

- Please consult your system's seal manufacturer for recommendation of seal selection, as Anchor Fluid Power does not accept responsibility for seal selection.

MAXIMUM & MINIMUM WORKING TEMPERATURES FOR SEAL MATERIALS

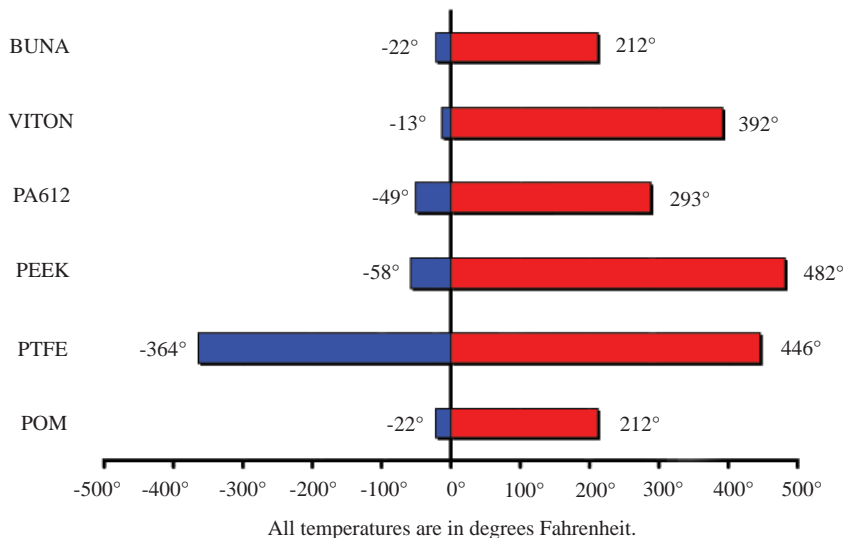

FLOW, NEEDLE & CHECK VALVES

HYDRAULIC BALL VALVES

WELD COUPLINGS

FLANGES