

# AE3K Series / Three-Way Block Body Threaded

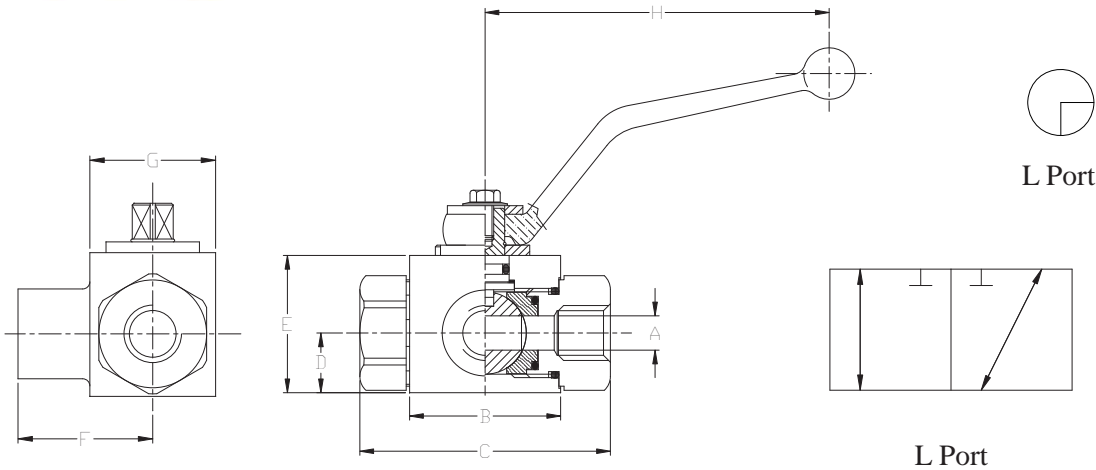

- Any port may be pressurized on this series valve ("True" 3-way valve)
- Carbon steel construction with Silver Trivalent plating
- POM seats & Buna O-rings standard on carbon steel valves
- Optional seal materials available for extreme temperature applications & fluid compatibility (Consult Factory)



Standard handles supplied are:  
Refer to page 47 for details.

1/8" - 1/2"  
3/4" - 1"

C1010ZB  
C1200ZB

AE3K SERIES FULL BORE											
NPT	SAE	PSI MAX	A BORE	B	C	D	E	F	G	H	WEIGHT
AE3K L N1/4	AE3K L S#4	5800	.24	1.65	2.80	.55	1.38	1.32	1.18	4.31	1.1 LBS
AE3K L N3/8	AE3K L S#6	5800	.39	1.73	2.87	.67	1.57	1.46	1.38	4.31	1.5 LBS
AE3K L N1/2	AE3K L S#8	5075	.51	1.89	3.27	.71	1.69	1.57	1.46	4.31	1.8 LBS
AE3K L N3/4	AE3K L S#12	5075	.79	2.44	3.74	.91	2.17	2.05	1.77	7.00	3.3 LBS
AE3K L N1	AE3K L S#16	5075	.98	2.60	4.45	1.14	2.56	2.36	2.17	7.00	5.2 LBS

NPT threads in accordance with ANSI B.1.20.1 specifications.  
SAE threads in accordance with SAE J1926/1 specifications.

FLOW, NEEDLE & CHECK VALVES

HYDRAULIC BALL VALVES

WELD COUPLINGS

FLANGES



# AE3K Series / Three-Way Block Body Threaded

## Model Code Breakdown

AE3KL N1/2 \_ - 1 1 D B \_

### Valve Series •

### Port Type •

L	"Diverter" L-Port
---	-------------------

### Connection Type/Size •

N	NPT Pipe Thread
S	SAE Straight Thread

### Bore Restriction •

blank	Unrestricted Bore
R	Restricted Bore

### Body & Adapter Material •

1	Carbon Steel
---	--------------

### Ball & Stem Material •

1	Carbon Steel
---	--------------

### • Locking Kit or Optional Handle Code (See pages 42 & 43)

### • Adapter & Stem Seals

B	Buna- Standard
---	----------------

### • Ball & Stem Seats

D	POM- Standard
P	PEEK
N	PA612
X	PTFE w/metallic insert

- Please consult your system's seal manufacturer for recommendation of seal selection, as Anchor Fluid Power does not accept responsibility for seal selection.

## MAXIMUM & MINIMUM WORKING TEMPERATURES FOR SEAL MATERIALS

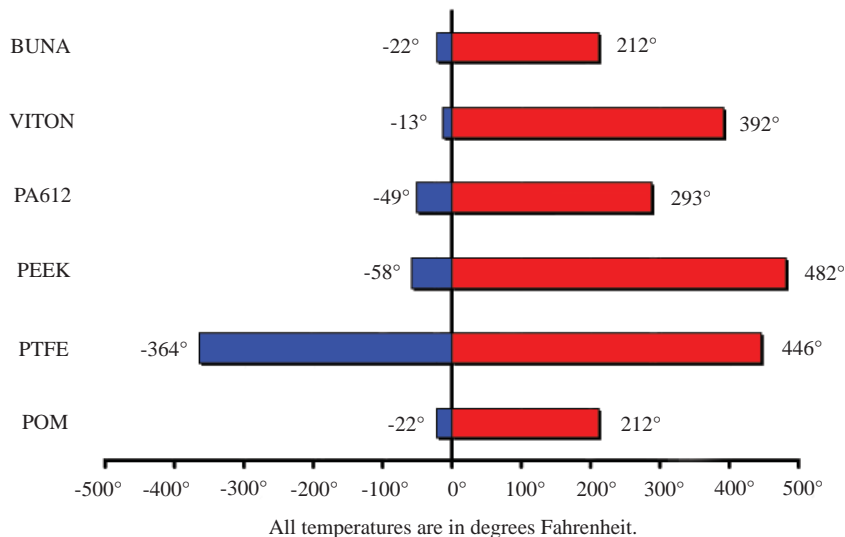

FLOW, NEEDLE & CHECK VALVES

HYDRAULIC BALL VALVES

WELD COUPLINGS

FLANGES